

Installation and Maintenance Manual for EMH[®] Freestanding Workstation Jib Cranes

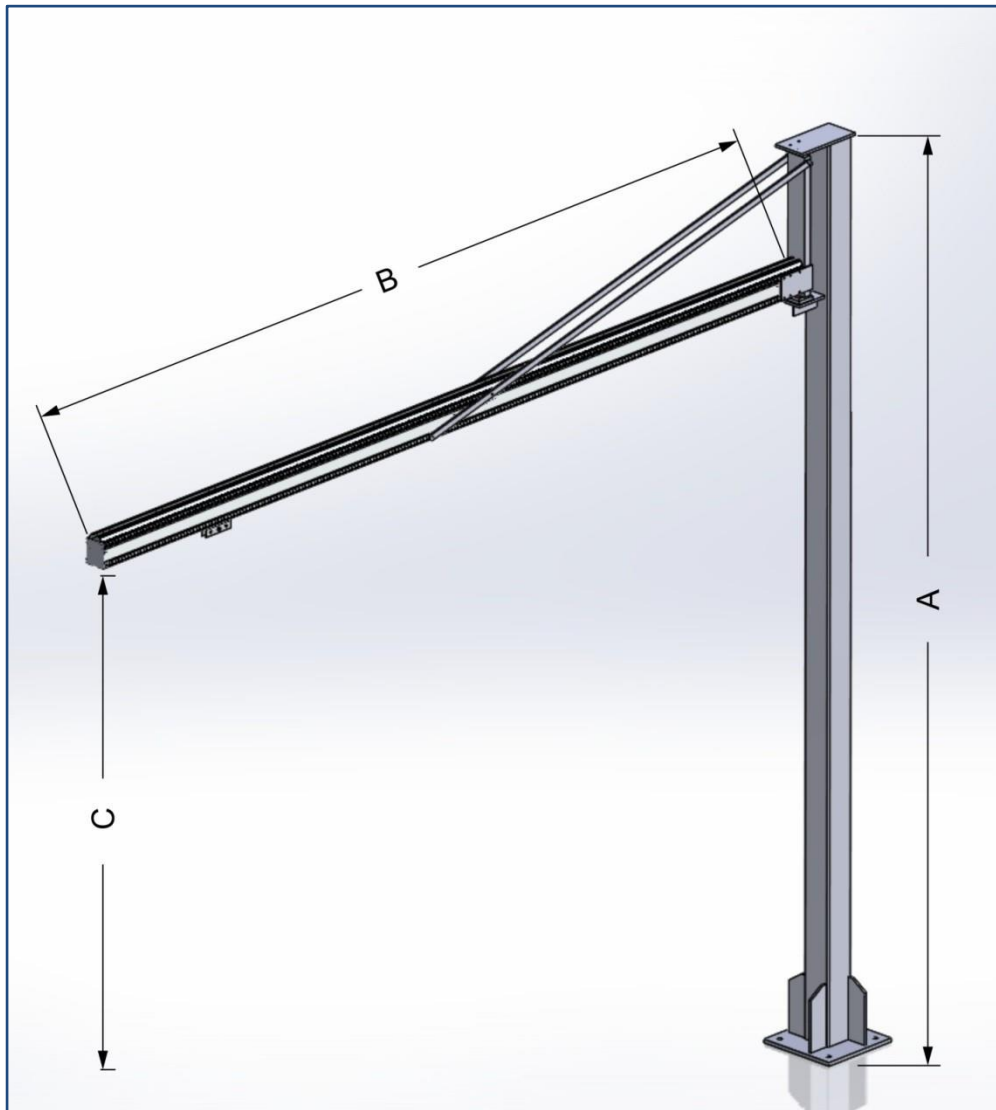

Installation and Maintenance Manual for EMH[®] Freestanding Workstation Jib Cranes

Table of Contents

Forward	3
Mast Installation.....	4-8
Manual Rotation Stop Installation.....	9
Boom Installation	9
Hoist Trolley and End Stop Installation	11
Festoon Options	11
Warning, Safety or Capacity Labels	12
Maintenance	12
Wall Mounted Jib Boom Installation	13
EMH Design Standards	14

Forward

This manual contains important information to help you install, operate, maintain, and service your new workstation jib crane. We recommend that you study its contents thoroughly before putting the jib into use. We also recommend that you obtain the latest issue of ANSI B30.11 Safety Standard for monorails and Underhung Cranes and study its contents thoroughly. By practicing the recommended maintenance suggestions, with proper installation, and application of correct operating procedures, you will be assured maximum service from your jib crane.

The jibs described in this manual are intended for indoor service. Jib cranes used for outdoor service require special consideration.



is subject to change without notice.

**THIS EQUIPMENT IS NOT, IN ANY WAY, DESIGNED FOR LIFTING,
SUPPORTING, OR TRANSPORTING HUMANS.**

Jib Crane Model: AL1

Maximum Lifted Load: 250 lbs.

Maximum Span without foundation: 15 ft. (per specifications below)

Connection of Jib Crane to an existing floor slab

When connecting to an existing floor slab, the following requirements must be met:

1. There must be NO visible cracks in the surface of the slab (including construction joints and control joints) within a radius of 8 feet from the center of the jib crane post. **
2. Minimum Slab Thickness: 5 inches

Connect Jib Crane Base Plate to existing floor slab using (4) adhesive anchors as follows:

1. Use Hilti HIT-HY 200 Adhesive System
2. Anchors

Use 3/4" diameter all thread rod (36 ksi min. yield strength) installed with 4" embedment.

3. Drilling and Cleaning: HAMMER DRILLED with COMPRESSED AIR cleaning of the drilled holes

4. Capacity Utilization:

57% with 3/4" anchors

**** If the existing floor slab has any cracks within an 8-foot radius of the center of the post, the jib must be installed on a new footing. The jib crane post shall be mounted at the center of the new footing as follows:**

Concrete Recommendations

1. Size: 6'-0" x 6'-0" x 1'-0" thick
2. Reinforcing: (6) #5 bars each way at top and bottom of footing with bars equally spaced
3. Concrete Strength: 3,000 psi min.
4. Reinforcing Bars: ASTM A615 Grade 60

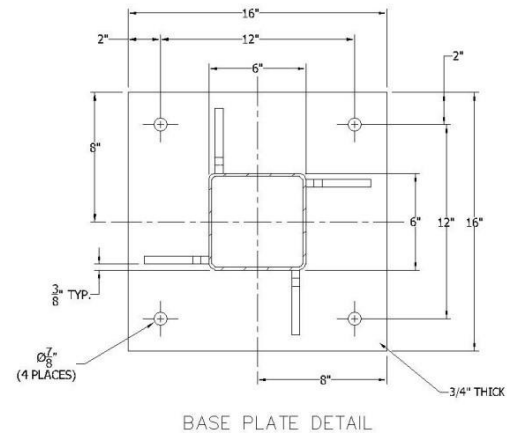
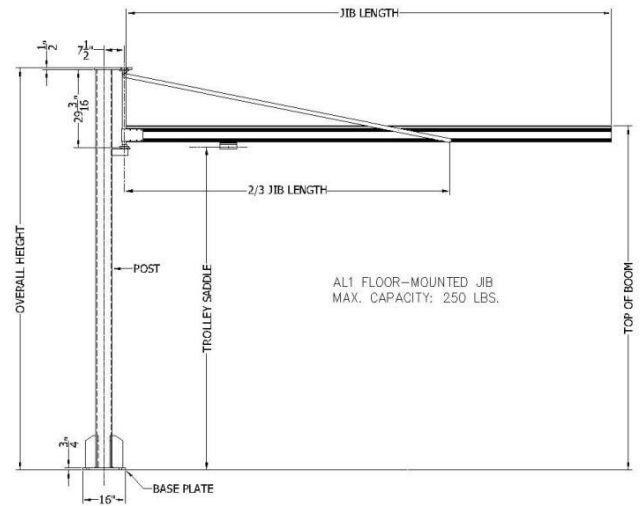

Jib Crane Model: AL2

Maximum Lifted Load: 500 lbs.

Maximum Span without Foundation: 10 ft. (per specifications below)

Connection of Jib Crane to an existing floor slab

When connecting to an existing floor slab, the following requirements must be met:

1. There must be NO visible cracks in the surface of the slab (including construction joints and control joints) within a radius of 8 feet from the center of the jib crane post. **
2. Minimum Slab Thickness: 6 inches

Connect Jib Crane Base Plate to existing floor slab using (4) adhesive anchors as follows:

1. Use Hilti HIT-HY 200 Adhesive System
2. Anchors
3/4" diameter all thread rod (36 ksi min. yield strength) installed with 4" embedment.
3. Drilling and Cleaning: HAMMER DRILLED with COMPRESSED AIR cleaning of the drilled holes
4. Capacity Utilization: 46%

**** If the existing floor slab has any cracks within an 8-foot radius of the center of the post, the jib must be installed on a new footing. The jib crane post shall be mounted at the center of the new footing as follows:**

Concrete Recommendations

1. Size: 6'-6" x 6'-6" x 1'-0" thick
2. Reinforcing: (7) #5 bars each way at top and bottom of footing with bars equally spaced
3. Concrete Strength: 3,000 psi min.
4. Reinforcing Bars: ASTM A615 Grade 60

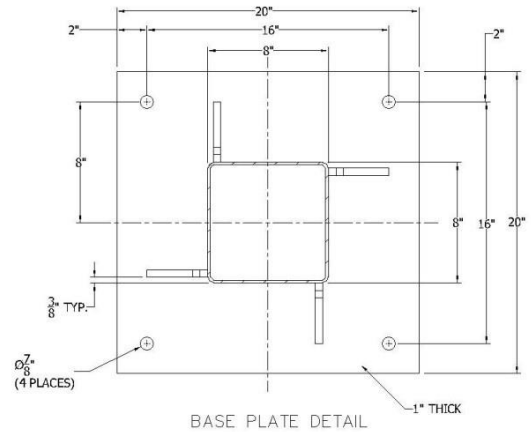
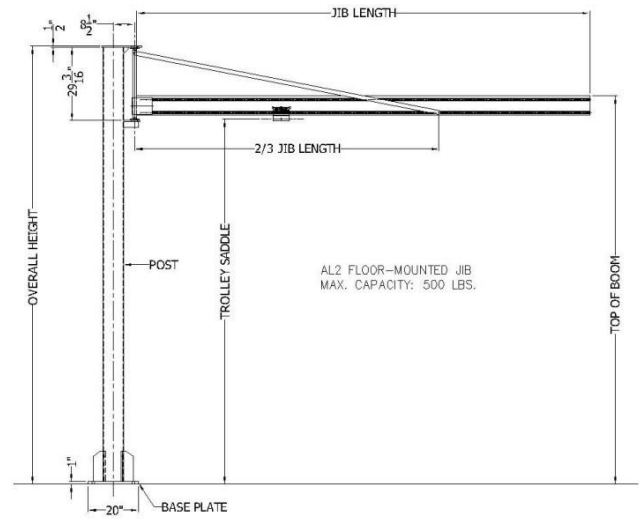

Jib Crane Model: AL3

Maximum Lifted Load: 1000 lbs.

Maximum Span without foundation: 12 ft. (per specifications below)

Connection of Jib Crane to an existing floor slab

When connecting to an existing floor slab, the following requirements must be met:

1. There must be NO visible cracks in the surface of the slab (including construction joints and control joints) within a radius of 9 feet from the center of the jib crane post. **
2. Minimum Slab Thickness: 8 inches

Connect Jib Crane Base Plate to existing floor slab using (4) adhesive anchors as follows:

1. Use Hilti HIT-HY 200 Adhesive System
2. Anchors
3/4" diameter all thread rod (36 ksi min. yield strength) installed with 5 1/2" embedment.
3. Drilling and Cleaning: HAMMER DRILLED with COMPRESSED AIR cleaning of the drilled holes
4. Capacity Utilization: 52%

**** If the existing floor slab has any cracks within an 8-foot radius of the center of the post, the jib must be installed on a new footing. The jib crane post shall be mounted at the center of the new footing as follows:**

Concrete Recommendations

1. Size: 7'-0" x 7'-0" x 1'-2" thick
2. Reinforcing: (8) #5 bars each way at top and bottom of footing with bars equally spaced
3. Concrete Strength: 3,000 psi min.
4. Reinforcing Bars: ASTM A615 Grade 60

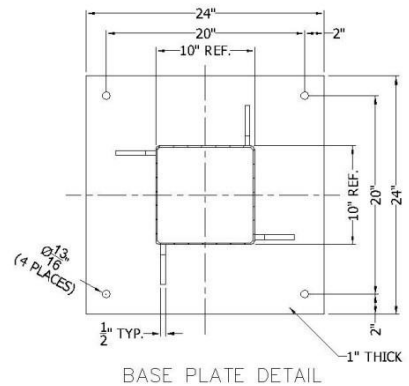
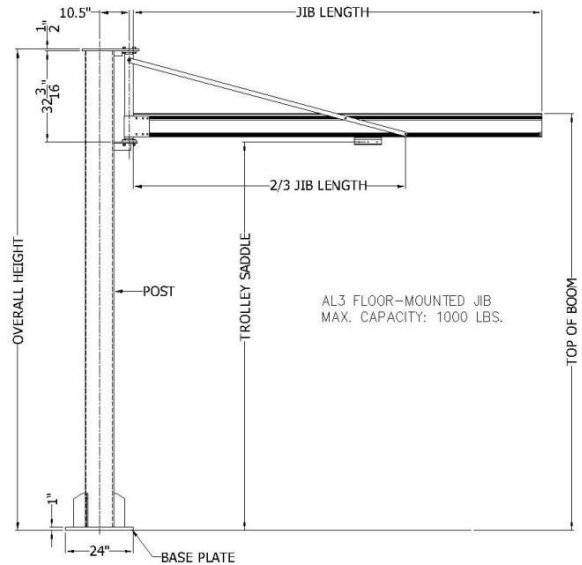

MAST INSTALLATION

Note: There are several types of base plate leveling methods to be used.

1. No shims or grout on a level and true concrete surface.
2. Using shims (by others) and grout, as required, or plumb the mast on an irregular concrete surface. (Be aware that the slightest deviation from level will be magnified by the height of the mast and will result in difficulty leveling the boom.)
3. A preset leveling plate (by others) and grout.
4. Using leveling nuts (by others) and grout, as required.

For purposes of this manual, we will describe method four, leveling nuts and grout. Other methods are similar, and may require special attention to anchor bolt projection lengths, grout thickness, and other on-site variables. In all cases, the finished installation requires full contact of the base plate on the foundation. All anchor bolts shall have plate washers (with standard holes) of adequate thickness for oversized base plate holes, per AISC requirements. Along with plate washes, a standard washer shall be used on each anchor bolt.

IT IS SOLELY THE CUSTOMER'S RESPONSIBILITY TO PROVIDE THE PROPER FOUNDATION FOR THE JIB CRANE SO THERE SHOULD BE NO DEVIATION FROM THE RECOMMENDED FOUNDATION SIZE OR INSTALLATION RECOMMENDATIONS WITHOUT FIRST CONSULTING A QUALIFIED PROFESSIONAL.

1. After installation the recommended concrete (3,000 PSI) foundation, reinforcement, and anchor bolts (minimum 3/4 inch diameter), refer to the dimension sheet of your specific model jib crane
2. Install one set of leveling nuts on the anchor bolts with the top surface approximately one inch above the foundation. Next, place the mast assembly over the anchor bolts resting on leveling nuts. Install the second set of nuts with plate washers and flat washers.
3. Once mast is secured over anchor bolts, plumb mast using a level on two adjacent faces.
4. Once mast is plumb, fully tighten anchor bolt hardware.
5. Verify that masts are still plumb.
6. **Do not grout until installation of boom is complete.**
7. When installation of crane is complete and the operation is double checked, float grouting compound under base plate and recheck tightness of locking nuts.

MAST INSTALLATION

(continued)

Figure 1

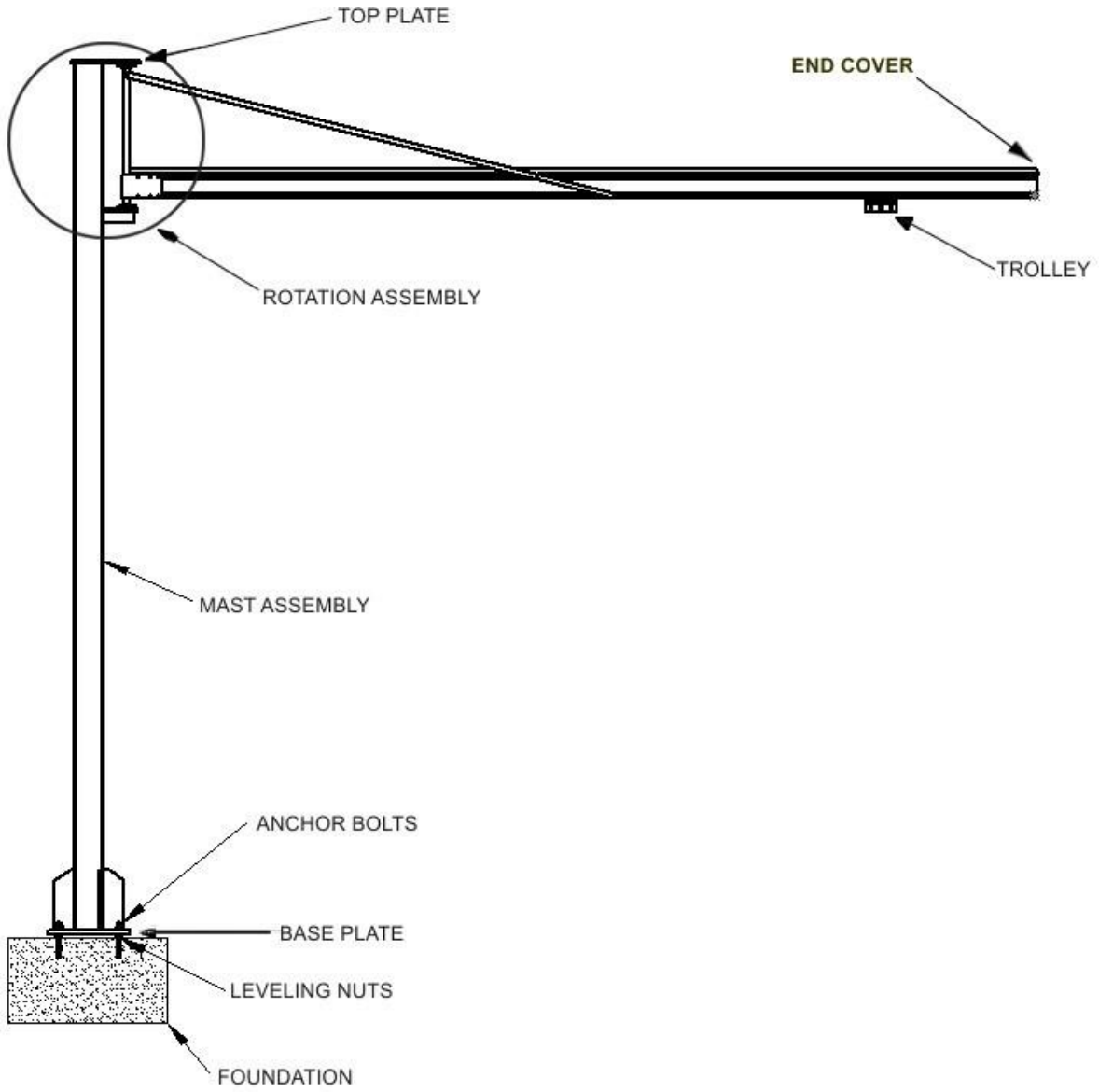

OPTIONAL ROTATION STOP INSTALLATION INSTRUCTION

BOOM INSTALLATION

Note: Do not install the boom until the mast is installed properly and plumbed.

1. Lay out rail for end stop location and drill for end stop.
2. Attach braces to shaft assembly. Lift rail and mount to track support and braces. Tighten all hardware.
3. Install load trolley and festoon system.
4. **NOTE: If boom and/or mast are not level, the trolley or boom will float or drift. If this occurs, readjust master boom for plumb/level as required.**
5. To compensate for anticipated deflection, it may be necessary to adjust boom with the tip raised.
6. When installation is complete and operation has been double checked, float grouting compound under base plate.

$$\text{Boom Length (inches)} \div 150 = \text{Deflection (inches)}$$

Figure 2

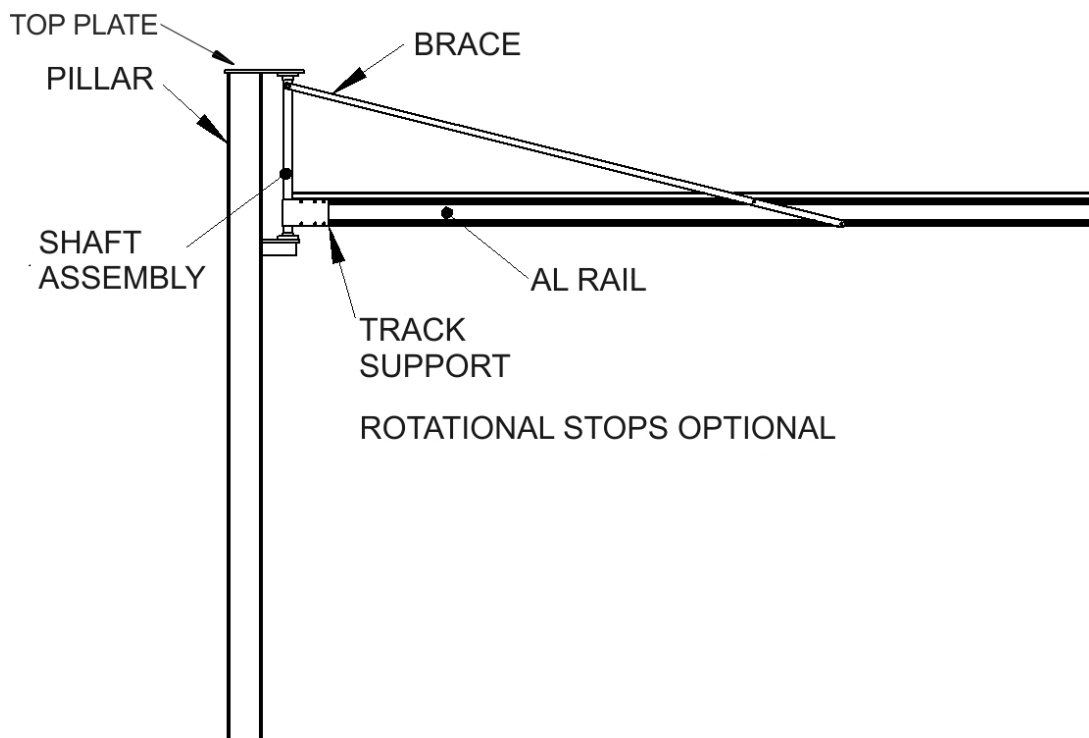
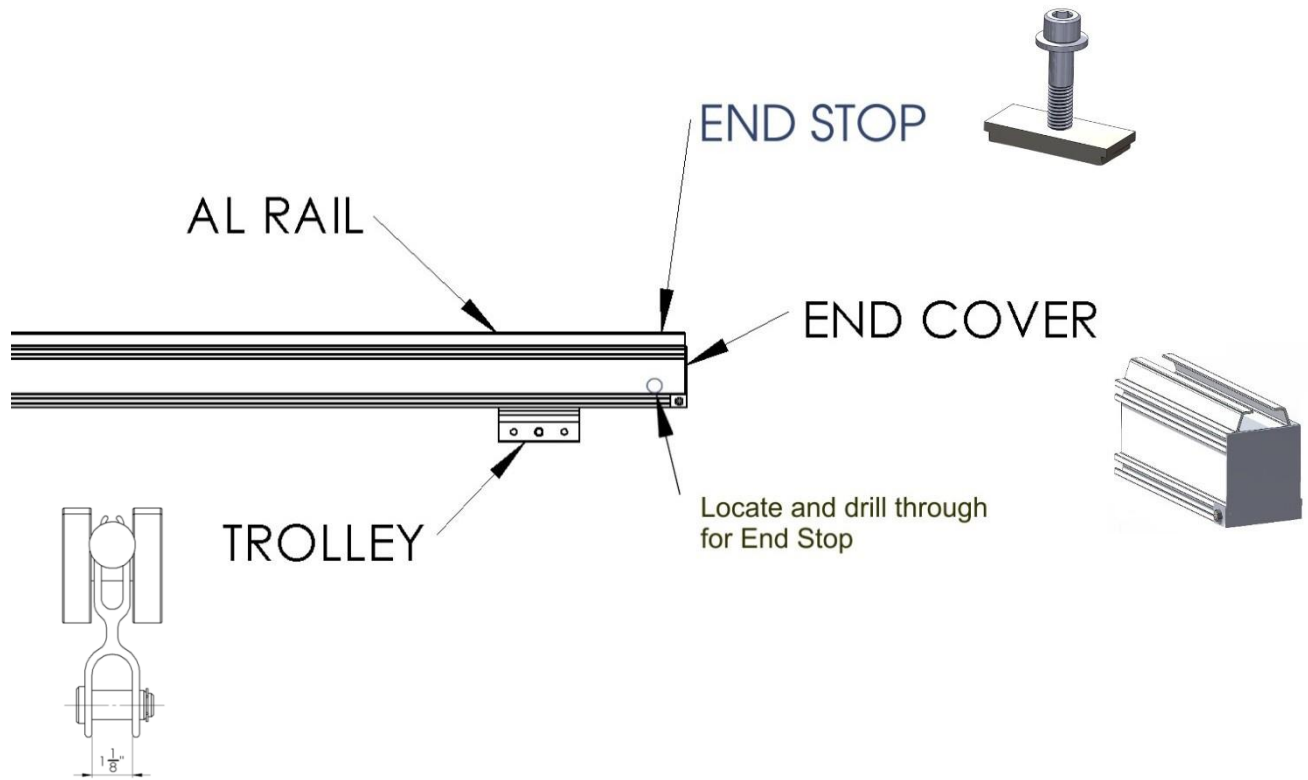

Figure 3



HOIST TROLLEY AND END STOP INSTALLATION

(Refer to Figure 2)

Note: This procedure may differ depending upon the festoon option you choose. (See Figures 4A, 4B, and 4C.) Festoon cables and trolleys are optional.

1. Place end clamp, festoon trolleys, then hoist trolley on the boom track. (See Figure 3.)
2. Secure the end stop bolts and rubber bumper.
3. Install the festoon cable on the festoon trolleys at equal spacing as required.
4. End stop at festoon stack-up end must be installed in front of festoon trolleys or sliders.

FESTOON OPTIONS

1. No festooning (Standard Cranes)
2. Vacuum hose trolleys (Figure 4A)
3. Coiled air (Figure 4B)
4. Position of end stops (Figure 4C)



Figure 4A



Figure 4B

Figure 4C



WARNING, SAFETY, OR CAPACITY LABELS

If at any time these labels are lost, stolen, removed, or become illegible, contact EMH, Inc. for free replacements at (330) 220-8600. Please order by part number on the label.

MAINTENANCE

Once installation is complete, the jib crane system should be checked thoroughly for tightness of nuts and bolts. In order to maintain efficient operating conditions, EMH recommends establishing a regular inspection and lubrication schedule. Inspection of all parts should be made. Loose parts should be adjusted and worn parts should be replaced immediately.

If a specific usage pattern cannot be determined, the crane operator or maintenance engineer should estimate when the crane should be lubricated. Generally, a jib crane operating 24 hours per day, seven days per week, requires lubrication once a week. A jib crane operating eight hours per day, five days per week requires lubrication once every two to three weeks. A jib crane operating once or twice a month requires lubrication at least once every six months.

Note: The points requiring lubrication are the main pivot bearing.

RECOMMENDED LUBRICANTS:

NLGI No. 1 or No. 2 greases.

Boom Installation for Wall Mounted Jib

Stop!

Do not proceed if your support structure does not meet the standard loading requirements.

Warning!

Consult a qualified structural engineer if you deviate from the recommended dimensions provided in this manual. EMH, Inc. is not responsible for any deviation from these foundation recommendations.

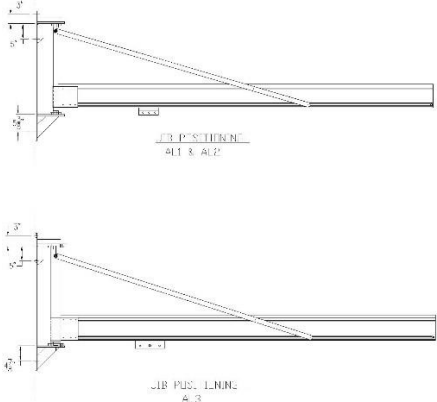
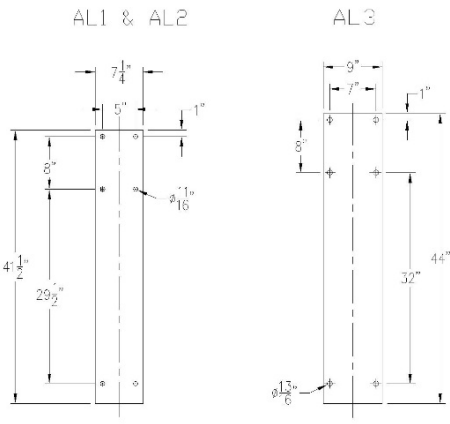
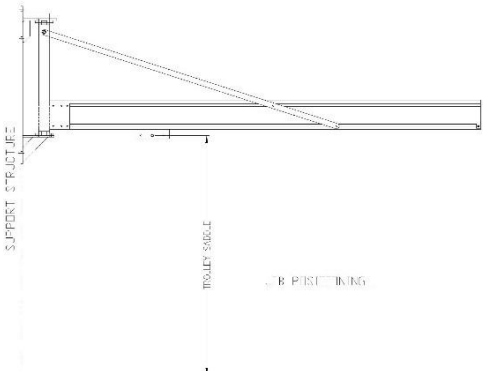
<p>1. Determine position of jib mounting on support structure.</p> 	<p>2. Lay out and drill bolt holes for shaft assembly to support structure.</p>  <p style="text-align: center;">MOUNTING PLATE DETAIL</p>
<p>3. Lift wall jib up and bolt to column holes.</p> 	<p>4. Check that assembly shaft of crane is plumb.</p> <p>5. Once shaft is plumb and shimmed, tighten all mounting bolts to manufacturer's specification.</p> <p>6. Carefully swing boom through entire travel to ensure boom is clear of obstructions and does not drift.</p>

EMH Design Standards

All EMH Work Station and Jib Cranes are structurally designed in accordance with the **AISC Steel Construction Manual**.

All EMH Jib and Work Station Cranes are in accordance with **OSHA Specification 1910.179** and **ANSI Specification B30.11**, as they apply to Jib and Overhead Cranes. All EMH Work Station Cranes meet or exceed the requirements of **MMA MH27.2** specification for enclosed track systems.

All Work Station Cranes are in accordance with the following Canadian Standards as they apply to Overhead Cranes: **CSA Standard B167-96 and CSA Standard C22.2 No.33-M1984 (reaffirmed 2004)**

All EMH Jib and Work Station Cranes have a design factor of 15% of the allowable capacity for hoist weight and 25% of the allowable capacity for impact.

Fabrication Standards: All welding is in accordance with **AWS D14.1**, and is performed by certified welders.

All holes in steel with bearing loads are either punched or drilled. Flame cut holes are not permitted in these applications.

Material Standards: All structural shapes used by EMH are a minimum of **ASTM A-36** designation. All pipes are structural grade **ASTMA-53** and all tubing is **ASTMA-500**.

All plate and round bar has **minimum yield strength of 36 KSL**

Painting Procedure: All structural components are shot blasted and/or washed utilizing a high pressure/high temperature iron phosphate solution prior to painting. A conventional air-assisted airless paint system is used to apply a high solids industrial baking enamel which is cured at elevated temperatures inside an industrial oven.

Deflection Guideline:

Consider both deflection and stress. The difference in elevation of the track between an unloaded crane and fully loaded crane; measure in inches. L= support center distance. EMH tends to have stricter deflection guidelines than others in the industry because we consider both deflection and stress.

- **Work Station Cranes:** Typical design guidelines are L/450 for bridge cranes
- **Work Station Jib Cranes:** Typical design guidelines are L/320 for wall mounted (WSJ200), L/200 for free standing (WSJ360), and L/450 for aluminum work station jibs (AL100).

Jib Cranes: Typical design guidelines are L/150 for wall cantilever (WC), free standing (FS), and mast type (MT), and L/450 for wall bracket (WB) cranes. Due to configuration restrictions, some models may not meet these guidelines.