

**ELV**

**Top Running**

**Single Structural Girder**

**Cranes**

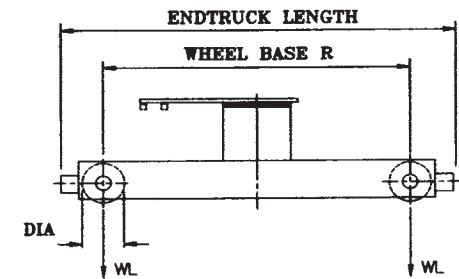
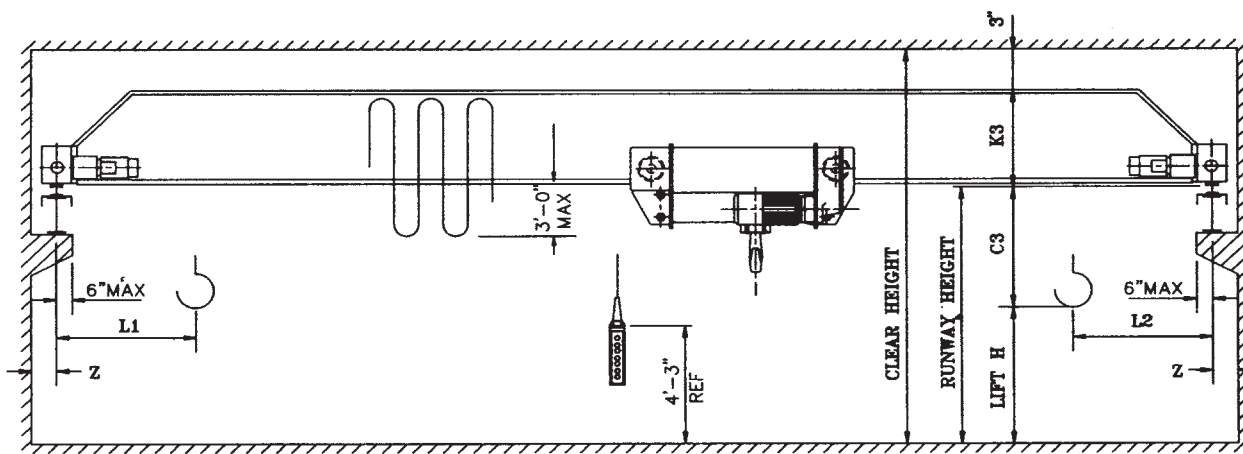

- Notes:
1. Runway electrification is standard on left side.
  2. Wheel loads do not include impact.
  3. The hook approach may be affected by the location of the runway electrification system.

## Single Girder Crane Type ELV2

Cap. Tons	Hoist		Lift Ft.	Trolley		Endtruck			Bridge						Wheel Load max Lbs.	Shipping Weight Lbs.	
	Type Reeving	Speed FPM		HP per Motor	Type Weight	HP per Motor	Wheel		HP per Motor	Span Ft.	L1 In.	L2 In.	C3 In.	K3 In.			Z In.
							Dia. In.	Base Ft.-In.									
2	820 4/1 0.25	16/2.6 4.1/0.68	20	EM820L6 163.41.060 680	.29/0.07	4	5'	6'	2x0.75	24	34	25	16	24	6	2672	2820
										28						2771	3100
										32						2928	3640
										36						3090	4220
										40						3268	4880
										44						3464	5620
										48						3648	6320
										52						3866	7160
										56						4011	7713
										60						4272	8734

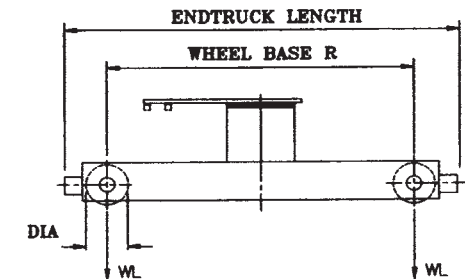
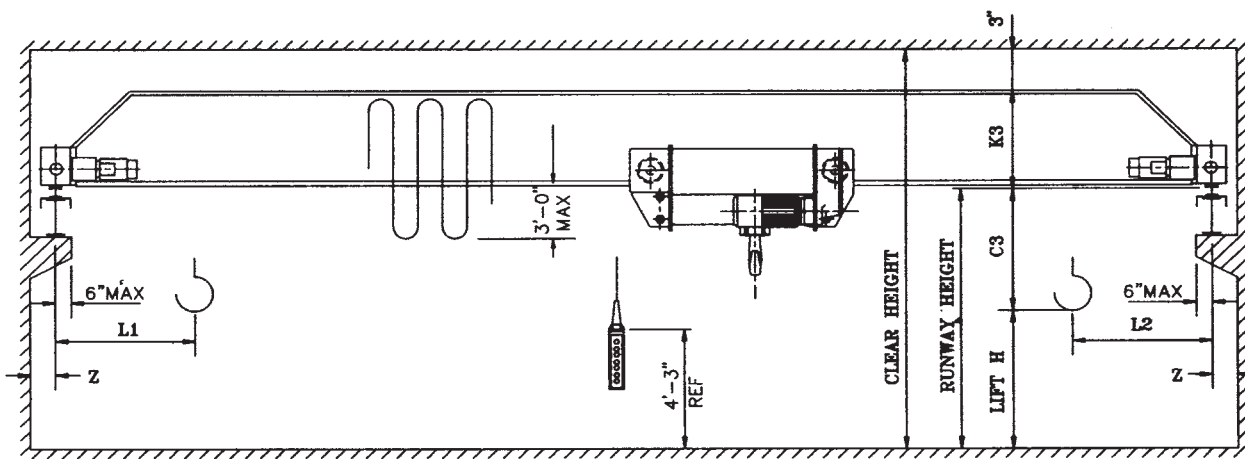

- Notes:
1. Runway electrification is standard on left side.
  2. Wheel loads do not include impact.
  3. The hook approach may be affected by the location of the runway electrification system.

## Single Girder Crane Type ELV3

Cap. Tons	Hoist		Lift Ft.	Trolley		Endtruck			Bridge						Wheel Load max Lbs.	Shipping Weight Lbs.			
	Type Reeving	Speed FPM		HP	Type	HP per Motor	Wheel		HP per Motor 120 FPM VFD	Span Ft.	L1 In.	L2 In.	C3 In.	K3 In.			Z In.		
							Dia. In.	Base Ft.-In.										Length Ft.-In.	
3	832 4/1 0.25	16/2.6 4.1/0.68	20	EM832L6 162.41.060 680	0.31/0.075	4	5'	6'	2x0.75	34	26	15	6	20	3636	3070			
																	28	3754	3370
																	32	3911	3870
																	5	2765	4170
																	40	4182	4770
																	44	4373	5470
																	48	4437	5670
																	52	4523	5970
																	56	4733	6770
																	60	4867	7270
																	8'-10"	9'-11"	

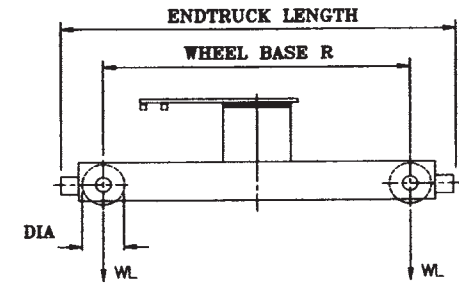
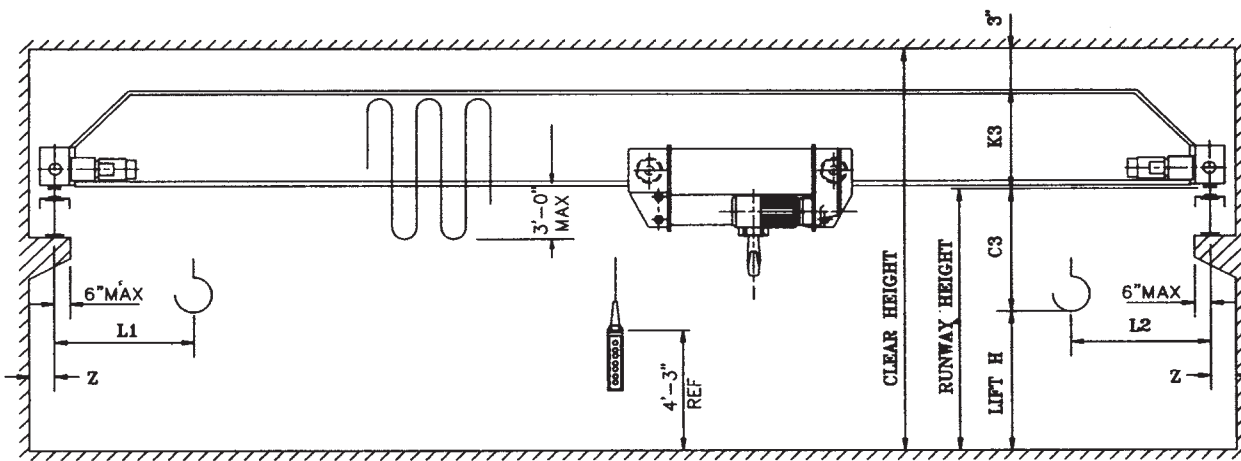

- Notes:
1. Runway electrification is standard on left side.
  2. Wheel loads do not include impact.
  3. The hook approach may be affected by the location of the runway electrification system.

## Single Girder Crane Type ELV4

Cap. Tons	Hoist		Lift Ft.	Trolley		Endtruck			Bridge						Wheel Load max Lbs.	Shipping Weight Lbs.					
	Type Reeving	Speed FPM		Type Weight	HP per Motor	Wheel Dia. In.	Base Ft.-In.	Length Ft.-In.	HP per Motor 120 FPM VFD	Span Ft.	L1 In.	L2 In.	C3 In.	K3 In.			Z In.				
	Rope Dia.	HP			65/16 FPM																
5	1050 4/1 0.4	16/2.6  5.7/1	20	EM1050L6 161.41.060 1225	0.6/0.15	4	5'	6'	2x0.75	36	30	20	25	6	24	5946	4798				
															28	6181	5401				
															32	6320	5705				
															36	6552	6435				
															40	6807	7298				
															44	7055	8160				
	33	EM1050L6 161.41.100 1350				5	6'-3"	7'-4"							48	7410	9471				
															52	7727	10650				
															56	8123	12155				
															60	8549	13792				
															8'-10"	9'-11"					

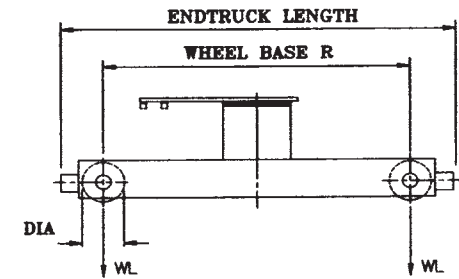
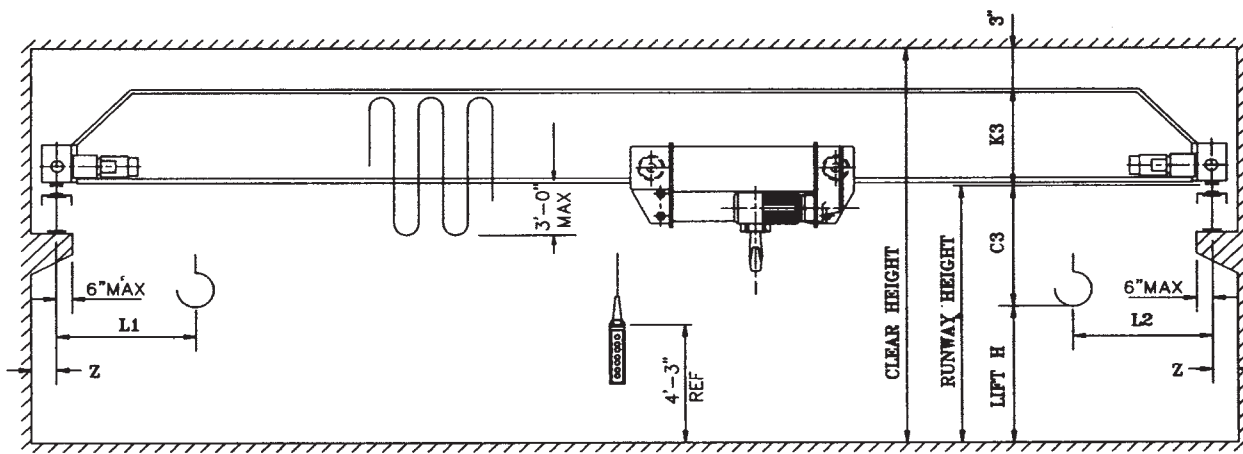

- Notes:
1. Runway electrification is standard on left side.
  2. Wheel loads do not include impact.
  3. The hook approach may be affected by the location of the runway electrification system.

## Single Girder Crane Type ELV5

Cap. Tons	Hoist			Trolley	HP per Motor 65/16 FPM	Endtruck			HP per Motor 120 FPM VFD	Bridge						Wheel Load max Lbs.	Shipping Weight Lbs.			
	Type Reeving Rope Dia.	Speed FPM HP	Lift Ft.			Type Weight	Wheel	Length Ft.-In.		Span Ft.	L1 In.	L2 In.	C3 In.	K3 In.	Z In.					
				Dia. In.	Base Ft.-In.															
7.5	2063 4/1 0.4	18/3  8.0/1.34	20	EM2063L6	0.6/0.15	5	5'	6'	2x0.75	24	40	36	23	25	6	8214	5330			
				181.41.060						28						8590	6240			
				1590						32						8820	6710			
			33	EM2063L6			181.41.100	1700		6'-3"						7'-4"	36	25	9154	7700
										40						26	9354	8220		
										44						26	9698	9370		
	6	7'-6"	8'-10"	10'-6"	2x1.00	6'-3"	7'-7"	48	26	10068	10660									
						52	26	10523	12320											
						56	30	10981	14014											
						8'-10"	10'-6"	60	30	11470	15850									

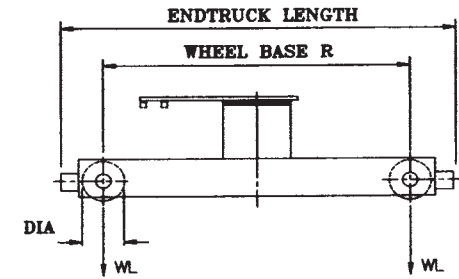
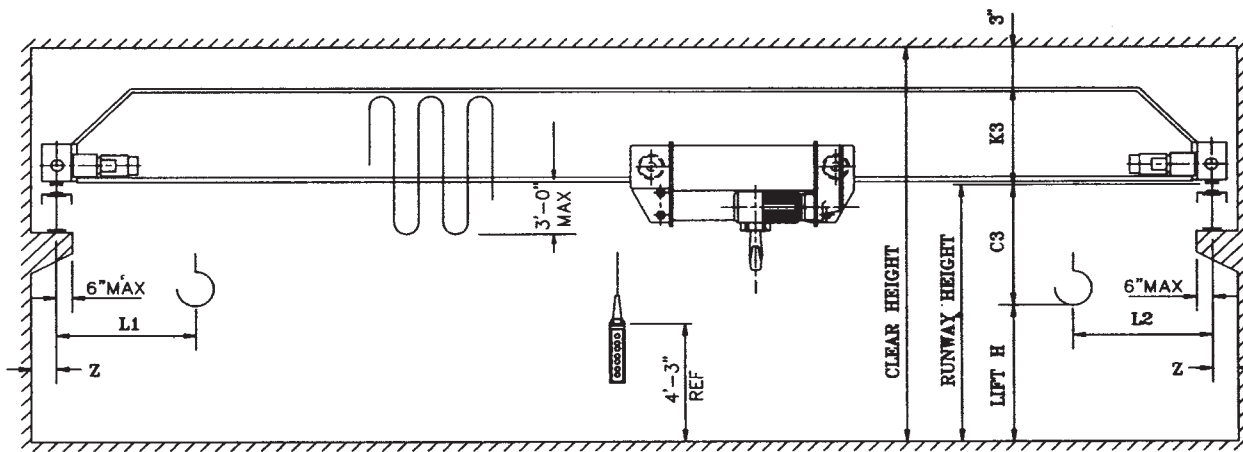

- Notes:
1. Runway electrification is standard on left side.
  2. Wheel loads do not include impact.
  3. The hook approach may be affected by the location of the runway electrification system.

## Single Girder Crane Type ELV6

Cap. Tons	Hoist			Trolley		Endtruck				Bridge						Wheel Load max Lbs.	Shipping Weight Lbs.
	Type Reaving Rope Dia.	Speed FPM HP	Lift Ft.	Type Weight	HP per Motor 65/16 fpm	Wheel		HP per Motor 120 FPM VFD	Span Ft.	L1 In.	L2 In.	C3 In.	K3 In.	Z In.			
						Dia. In.	Base Ft.-In.								Length Ft.-In.		
10	3100 4/1 0.5	16/2.6  10.3/1.8	20	EM3100L6 162.41.060 2230	0.6/0.15	6	6'-3"	7'-7"	2x1.00	24	40	36	23	26	6	11075	7513
										28						11405	8037
										32						11800	9018
										36						12211	10193
										40						12466	10840
										44						12885	12212
										48						13149	13015
	8	7'-3" 8'-10"	8'-10" 10'-4"	2x1.5	52	13610	14643										
					56	14052	16227										
					60	14798	19048										