

Specifications for EMH Style HSE160 Top Running Single Girder Endtrucks - 6.5 in. Diameter Wheels WheelBase: 3200/3800 mm.

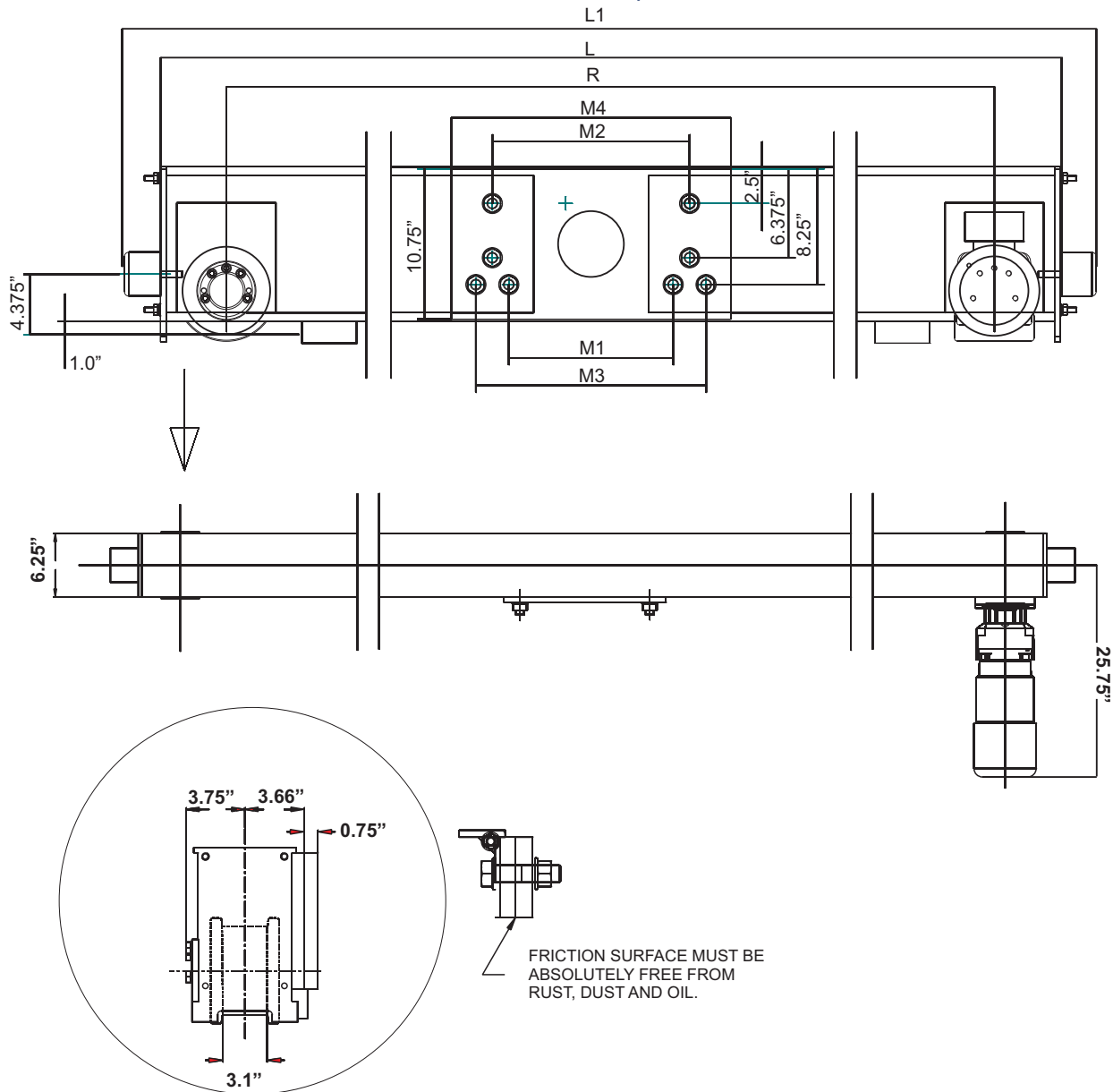

Model No.	Wheel Load	Moving Mass Lbs.	120 fpm Motor HP	Wheel Base (R) Ft.-In.	L Ft.-In.	L1 Ft.-In.	M1 In.	M2 In.	M3 In.	M4 In.	Weight per Pair
HSE-160.274.3200	14,550	35,200	2 x 1.0	10-6	11-4	11-10	14.6	16.9	19.3	23	1442
HSE-160.274.3800	12,250	35,200	2 x 1.0	12-6	13-4	13-10	16.5	18.9	21.25	25	1632