

# Specifications for EMH Style DLVM-160 Single Girder Under Running End Trucks 6.25 In. Diameter Wheels

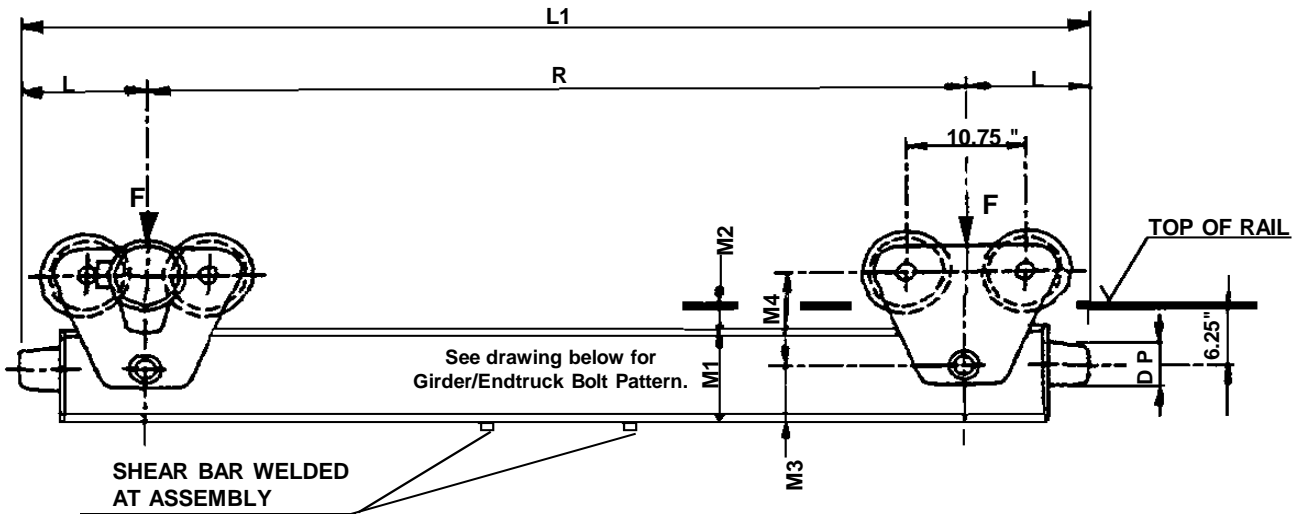

### Girder/Endtruck Bolt Pattern

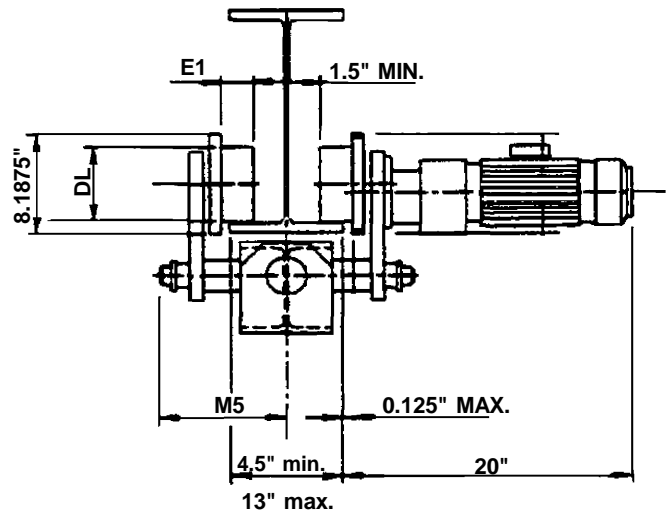
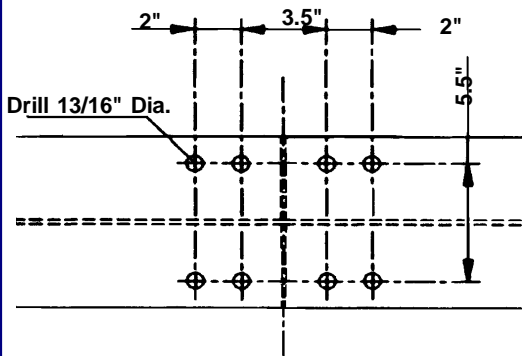

Consult EMH for wider flange or patented track.

Model No.	Wheel Base (R) Ft.-In.	Corner Load Lbs. (F)	Movable Mass Lbs.	Endtruck Load Max. Lbs.	120 fpm Motor HP	Max Span Ft.	Wt. Lbs.	L In.	L1 Ft.-In.	DL In.	DP In.	E1 In.	M1 In.	M2 In.	M3 In.	M4 In.	M5 In.
D-160.275.1720.1	5-6	15,000	36,000	30,000	1.0	39	1260	9	7-0	6.25	3	1.125	8.75	2.125	5.5	8.5	9
D-160.275.2000.1	6-6	15,000	36,000	30,000	1.0	52	1540	9	8-0	6.25	3	1.125	8.75	2.125	5.5	8.5	9
D-160.275.2300.1	7-6	15,000	36,000	30,000	1.0	64	1670	9	9-0	6.25	3	1.125	9	2.125	5.75	8.5	9