

Specifications for EMH Wheel Blocks 5, 6.5, 8, 10, 12 and 16 In. Diameter Wheels

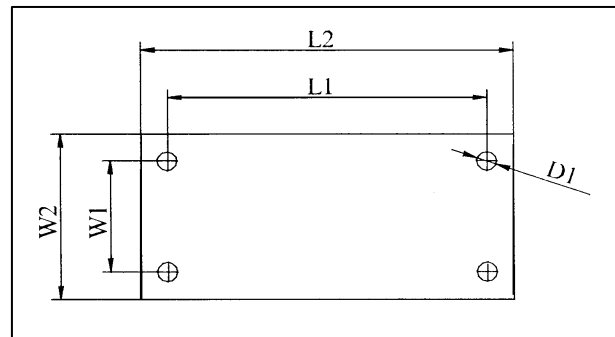
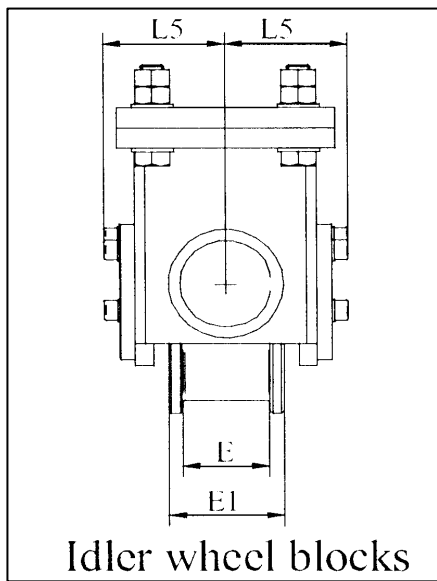
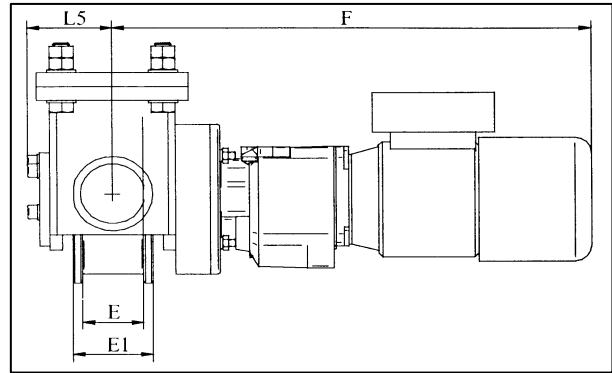
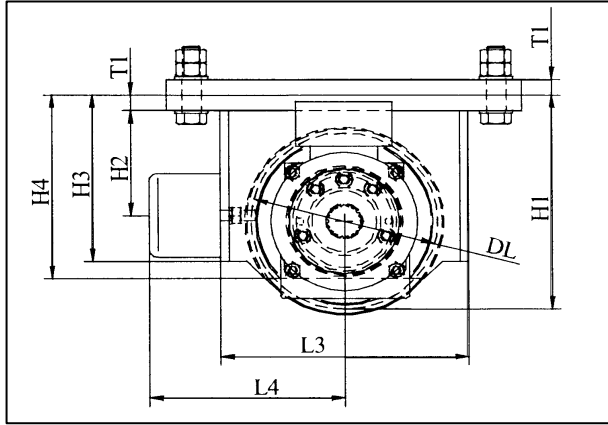

Model No.	DL In.	Rmax Lbs.	Mmax Lbs.	SP (FPM)	HP	Wt. Lbs.
HWB-130	5	11240	24,000	120	0.75	67
HWB-160	6.5	15730	35,200	120	1.00	93
HWB-200	8	22480	63,000	120	1.50	172
HWB-250	10	35970	93,500	120	2.00	260
HWB-315	12	49455	140,000	120	3.00	383
HWB-400	16	59350	200,000	120	5.00	685

Model No.	L1 In.	L2 In.	L3 In.	L4 In.	L5 In.	H1 In.	H2 In.	H3 In.	H4 In.	W1 In.	W2 In.	D1 In.	T1 In.	E In.	E1 In.	F In.
HWB-130	9	10.5	7.2	6.2	3.5	6.4	3.5	5.6	6.4	3.5	6.1	11/16	0.43	2.6	3.9	20
HWB-160	11	13	8.5	6.9	3.8	7.6	4.5	6.7	7.6	3.5	6.5	11/16	0.43	3	3.9	22
HWB-200	13.5	16	11	8.7	4.2	9.4	5.3	7.8	9.4	5	7.5	13/16	0.75	3	3.9	24
HWB-250	15	17	13	10	4.6	12	6.8	10.8	11.7	5	7.5	33/32	0.95	3	4.5	27
HWB-315	18	20	15	11.5	5.1	14.2	8	13.2	14.1	5	7.5	33/32	0.95	3.3	4.5	29
HWB-400	21	24	19	13.5	5.9	17.8	9.8	16.9	17.7	7.4	9.8	33/32	0.95	3.4	4.9	33