

ELV

Top Running

Single Structural Girder

Cranes

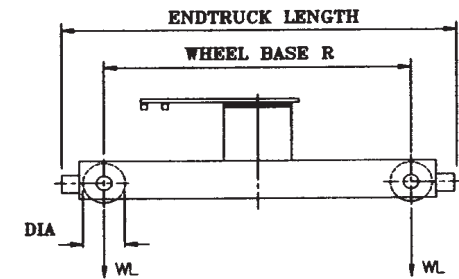
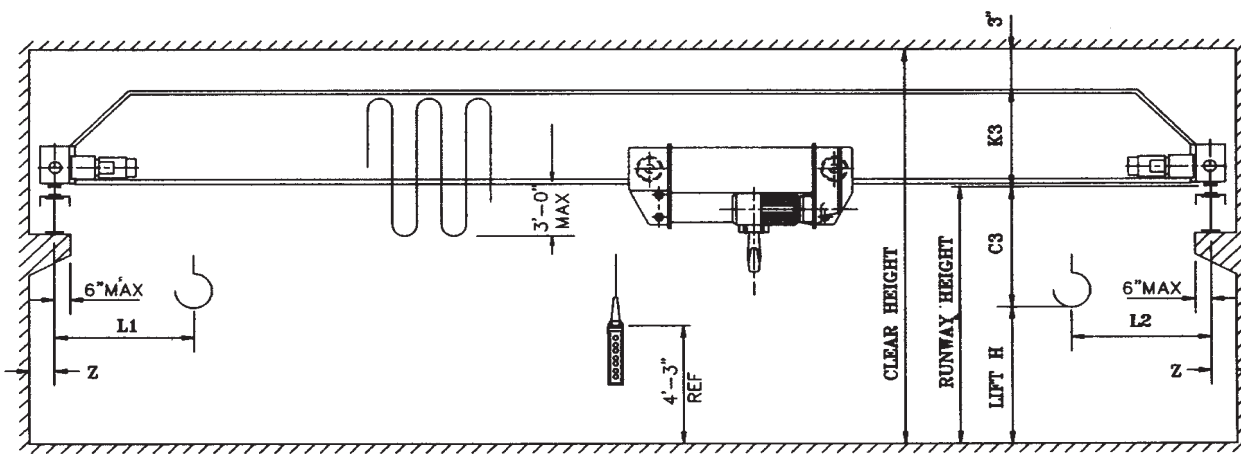

- Notes:
1. Runway electrification is standard on left side.
 2. Wheel loads do not include impact.
 3. The hook approach may be affected by the location of the runway electrification system.

Single Girder Crane Type ELV2

Cap. Tons	Hoist			Trolley		Endtruck				Bridge						Wheel Load Lbs.	Shipping Weight Lbs.
	Type Reeving Rope Dia.	Speed FPM HP	Lift Ft.	Type Weight	HP per Motor 65/16 FPM	Wheel		Length Ft.-In.	HP per Motor 120 FPM VFD	Span Ft.	L1 In.	L2 In.	C3 In.	K3 In.	Z In.		
						Dia. In.	Base Ft.-In.										
2	820 4/1 0.25	16/2.6 4/0.59	20	EM820L6 163.41.060 620	.29/.07	5	5'-0"	6'-2"	2x0.75	24	34	25	16	24	6	2700	2820
																2800	3100
																3000	3640
																3100	4220
																3200	4880
																3400	5620
	6'-3"	7'-5"	3500	6320													
			3600	7160													
			3942	7713													
			4210	8734													
			7'-6"	8'-8"													

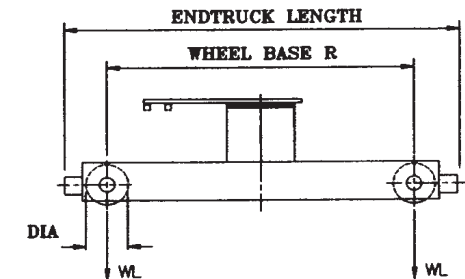
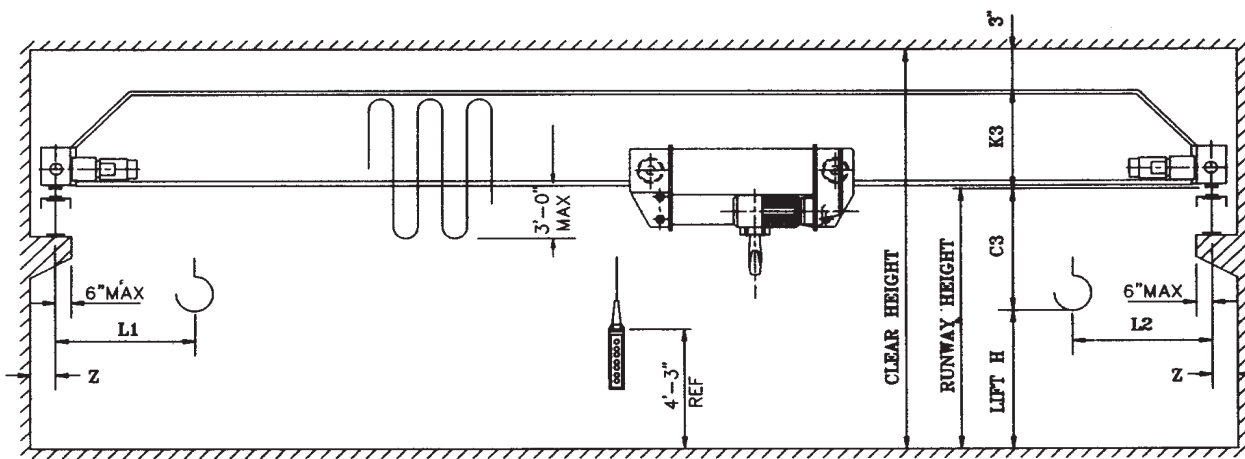

- Notes:
1. Runway electrification is standard on left side.
 2. Wheel loads do not include impact.
 3. The hook approach may be affected by the location of the runway electrification system.

Single Girder Crane Type ELV3

Cap. Tons	Hoist			Trolley		Endtruck			Bridge						Wheel Load Lbs.	Shipping Weight Lbs.		
	Type Reeving Rope Dia.	Speed FPM HP	Lift Ft.	Type Weight	HP per Motor 65/16 FPM	Wheel		Length Ft.-In.	HP per Motor 120 FPM VFD	Span Ft.	L1 In.	L2 In.	C3 In.	K3 In.			Z In.	
						Dia. In.	Base Ft.-In.											
3	832 4/1 0.25	16/2.6 4/0.59	20	EM832L6 162.41.060 620 lbs.	.29/.07	5	5'-0"	6'-2"	2x0.75	24	34	26	18	6	6	3515	3356	
																28	3706	3954
																32	3828	4325
							36	3979								4821		
							40	4200								5556		
							44	4445								6545		
						48	4672	7359										
						52	5017	8731										
						56	5389	10183										
						60	5928	12304										

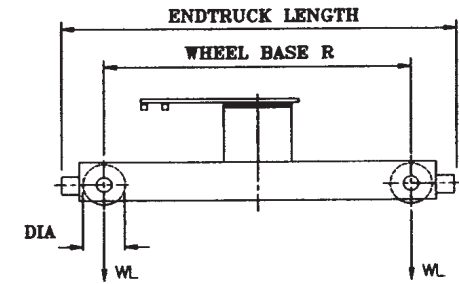
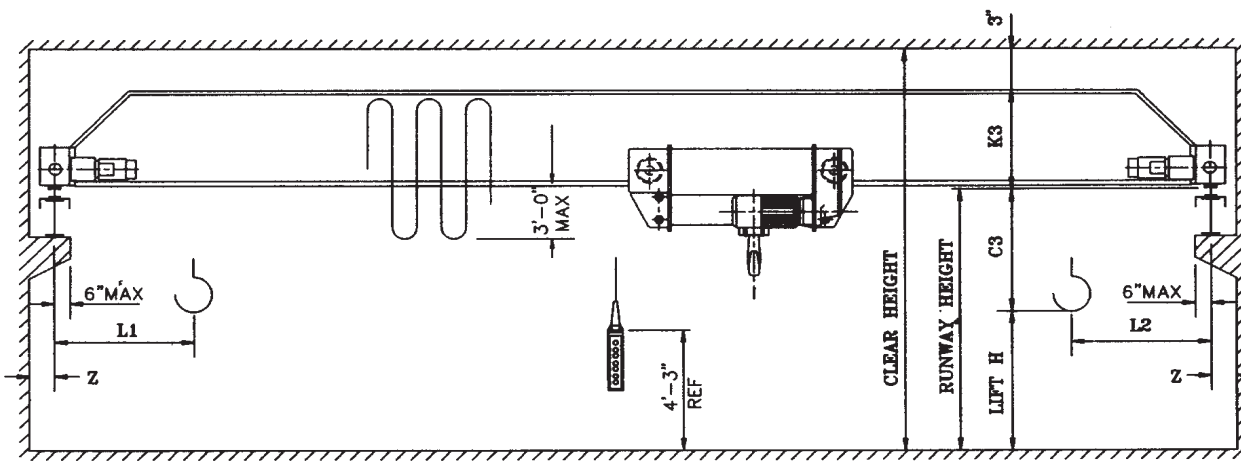

- Notes:
1. Runway electrification is standard on left side.
 2. Wheel loads do not include impact.
 3. The hook approach may be affected by the location of the runway electrification system.

Single Girder Crane Type ELV4

Cap. Tons	Hoist			Trolley		Endtruck				Bridge						Wheel Load Lbs.	Shipping Weight Lbs.				
	Type Reeving Rope Dia.	Speed FPM HP	Lift Ft.	Type Weight	HP per Motor 65/16 FPM	Wheel		Length Ft.-In.	HP per Motor 120 FPM VFD	Span Ft.	L1 In.	L2 In.	C3 In.	K3 In.	Z In.						
						Dia. In.	Base Ft.-In.														
5	1050 4/1 0.4	16/2.6 6.4/0.8	20	EM1050L6 161.41.060 775 lbs.	0.29/0.07	5	5'-0"	6'-2"	2x0.75	24	36	30	20	25	6	5716	4798				
																5941	5401				
																6073	5705				
																6299	6435				
																6549	7298				
			6793	8160																	
			7145	9471																	
			7459	10650																	
			7853	12155																	
			8277	13792																	
			33	EM1050L6 161.41.100 835 lbs.		6.5	7'-6"	8'-10"	28												

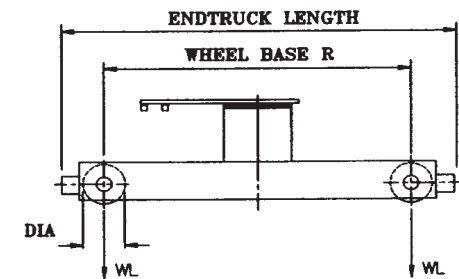
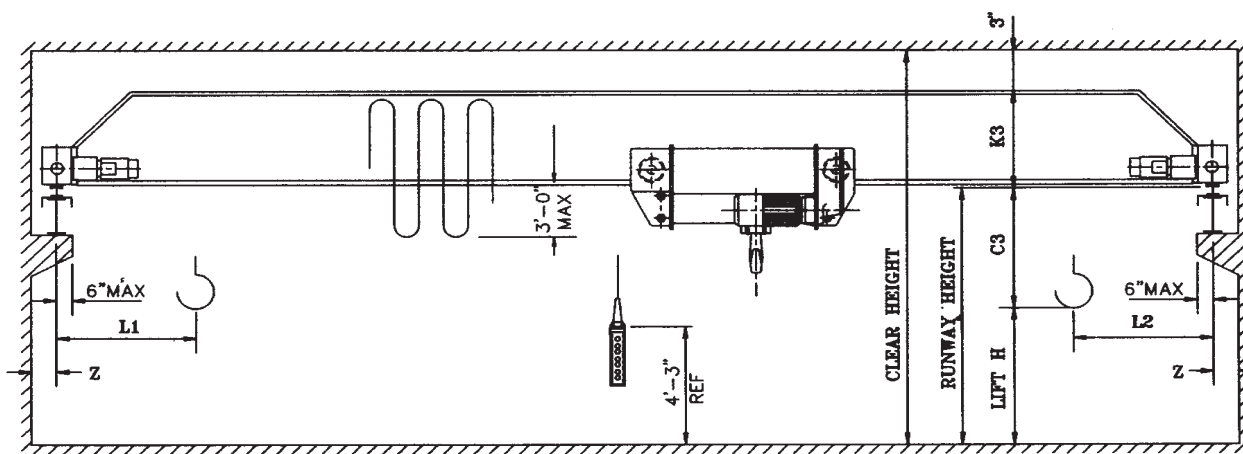

- Notes:
1. Runway electrification is standard on left side.
 2. Wheel loads do not include impact.
 3. The hook approach may be affected by the location of the runway electrification system.

Single Girder Crane Type ELV5

Cap. Tons	Hoist			Trolley		Endtruck			Bridge						Wheel Load Lbs.	Shipping Weight Lbs.	
	Type Reeving Rope Dia.	Speed FPM HP	Lift Ft.	Type Weight	HP per Motor 65/16 FPM	Wheel		HP per Motor 120/30 FPM	Span Ft.	L1 In.	L2 In.	C3 In.	K3 In.	Z In.			
						Dia. In.	Base Ft.-In.										Length Ft.-In.
7.5	2063 4/1 0.4	17/2.8 8.8/1.3	20	EM2063L6 171.41.060 1200 lbs.	0.40/0.10	6.25	6'-3"	7'-7"	2x0.75	24	40	36	23	25	6	8130	5330
										28				8460		6240	
										32				8660		6710	
										36				8970		7700	
										40				9150		8220	
										44				9480		9370	
										48				9845		10660	
	52	10280	12320														
	56	10730	14014														
	60	11211	15850														
				33	EM2063L6 171.41.100 1320 lbs.			7'-6"	8'-10"								

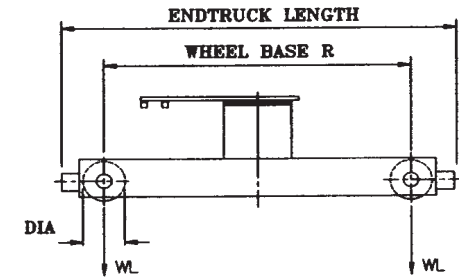
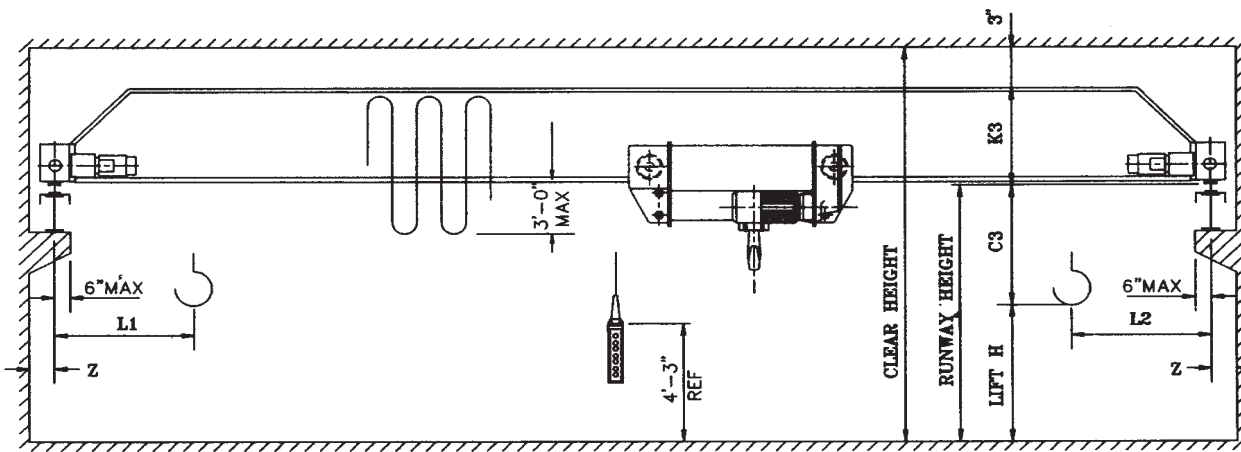

- Notes:
1. Runway electrification is standard on left side.
 2. Wheel loads do not include impact.
 3. The hook approach may be affected by the location of the runway electrification system.

Single Girder Crane Type ELV6

Cap. Tons	Hoist			Trolley		Endtruck				Bridge						Wheel Load Lbs.	Shipping Weight Lbs.			
	Type Reeving Rope Dia.	Speed FPM HP	Lift Ft.	Type Weight	HP per Motor 65/16 fpm	Wheel		Length Ft.-In.	HP per Motor 120 FPM VFD	Span Ft.	L1 In.	L2 In.	C3 In.	K3 In.	Z In.					
						Dia. In.	Base Ft.-In.													
10	3100 4/1 0.5	16/2.6 16/2.5	20	EM3100L6 162.41.060 2150 lbs.	0.59/0.14	8	6'-3"	7'-11"	2x1.0	24	40	36	23	26	6	10860	7513			
										28						11147	8037			
										32						11510	9018			
										36						11894	10193			
										40						12128	10840			
										44						12530	12212			
										48						12758	13015			
	52	13230	14643																	
	56	13662	16227																	
	60	14398	19048																	
				33	EM3100L6 162.41.100 2365 lbs.		7'-6"	9'-2"												